



HOW TO MEASURE FOR SPECIAL SHAPES



Special shapes measuring guide from British Shutters

www.britishshutters.co.uk

Special shapes are only available in louvered shutters. They are not available with solid panels.

A symmetrical window means the left side is the exactly the same as the right side. For a symmetrical shaped shutter manufacturing require **Width & Height** plus an **A, B, C** where instructed.

Perfect Arch section - height of the arch section must be **exactly half** the width of the base.

Non-Perfect Arch section - we need more measurements. Follow instructions at the end of guide.

A is the **Leg Height**. Above **Leg Height**, the arch shape **starts to form**, or the shape starts to change (e.g. Tapered)

Tips - Consider Z frame if walls are out of level. Using T posts & a Laser Measure tape

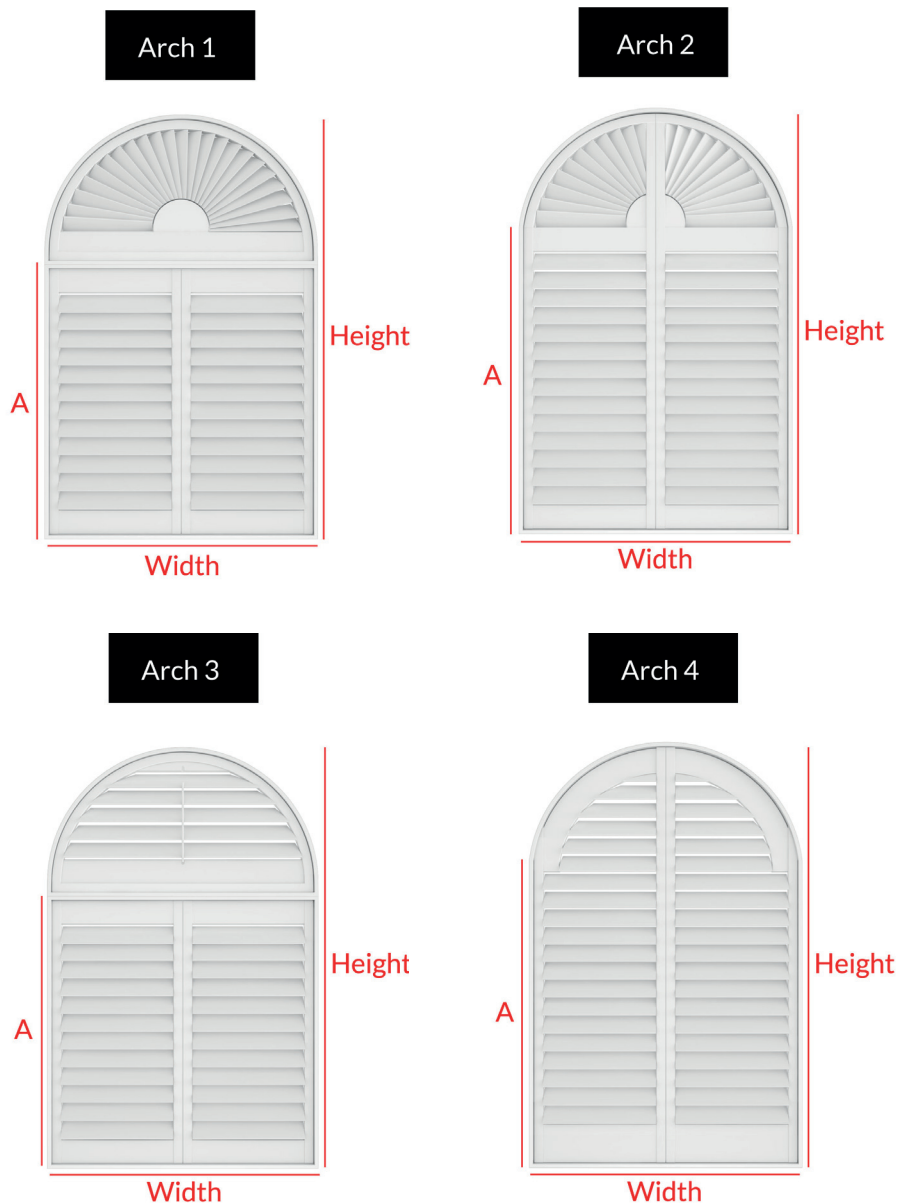

For **height**, measure from the very centre of the width to the **highest** point on the arch.

Measure **A** on both sides and submit the **smallest A** you find.

Please note:

Surcharge and longer lead time applies. A drawing must be signed off before production can begin.

Circle 1

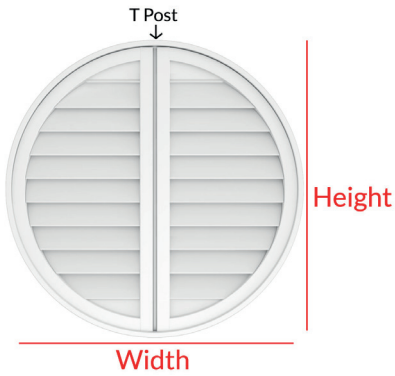

Circle 2

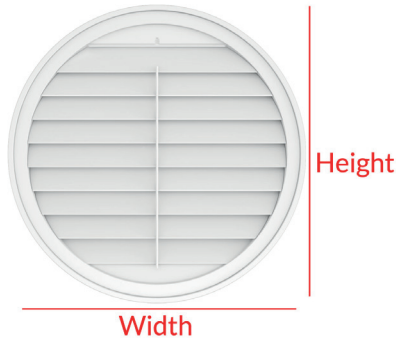

Circle 3

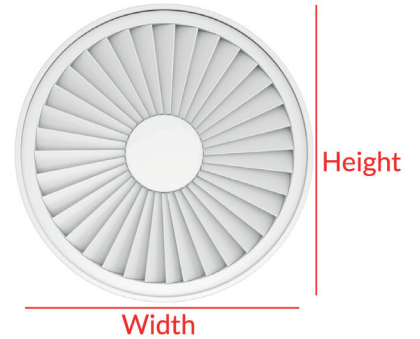

Circle 1 – 2 x panels hinge as RTL

Circle 2 & Circle 3 panel is held in frame via magnets

Sunburst 1



Sunburst 3



Elongated Sunburst 1



Elongated Sunburst 3

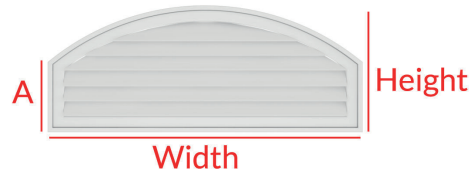

Tip – (type 1) - move slats by hand

(type3) - slats require central rod

For **height** measure from the very centre of the width to the **highest** point.

Measure **A** on both sides and select the **smallest A** you find.

Sunburst panels can hinge on the bottom to open downwards.

Please note:

Surcharge and longer lead time applies. A drawing must be signed off before production can begin.

Tapered 1 Left

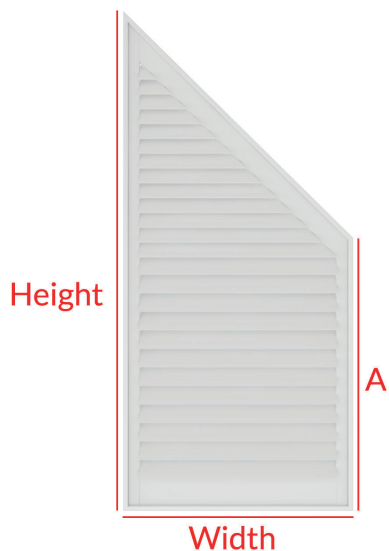

Hinge on Left

Tapered 1 Right

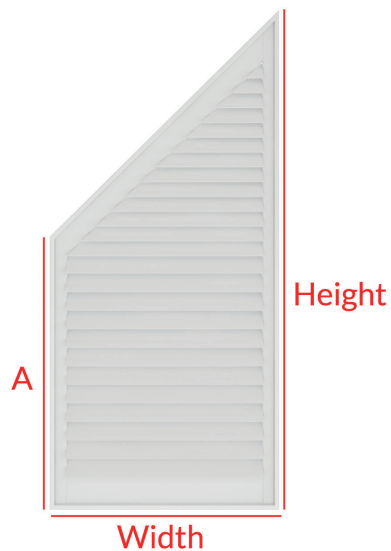

Hinge on Right

Tapered 2 Flat Top Left

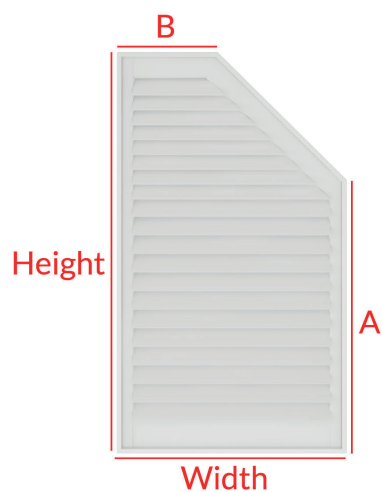

Hinge on Left

Tapered 2 Flat Top Right

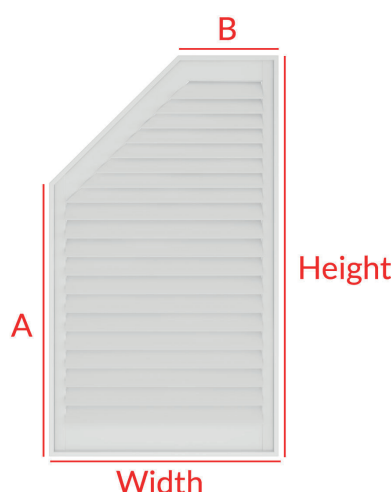

Hinge on Right

Please note:

Surcharge and longer lead time applies. A drawing must be signed off before production can begin.

Trapezoid 1

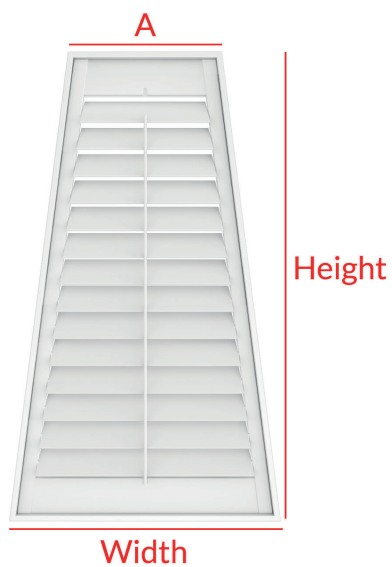

Hinge on Top

Triangle 1

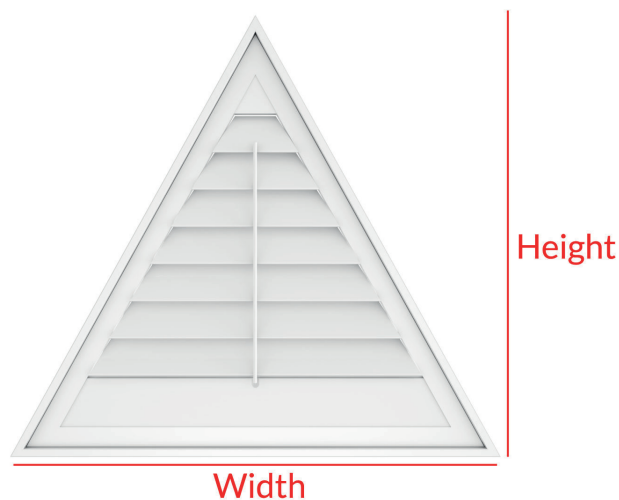

Hinge on Bottom

Trapezoid 2 Left

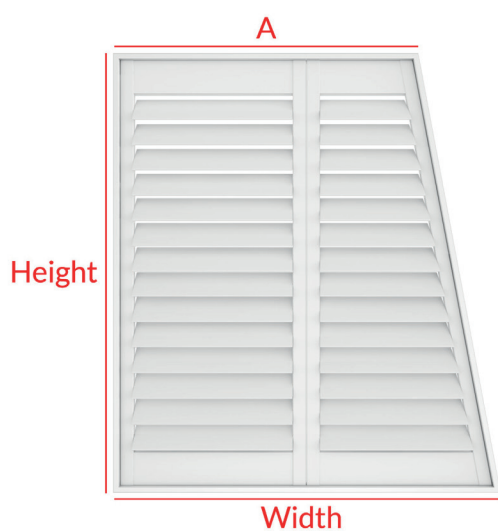

Hinge on Left

Trapezoid 2 Right

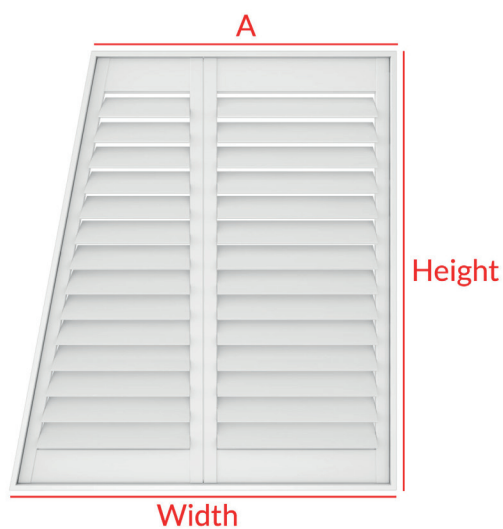

Hinge on Right

Please note:

Surcharge and longer lead time applies. A drawing must be signed off before production can begin.

Triangle 2 Left

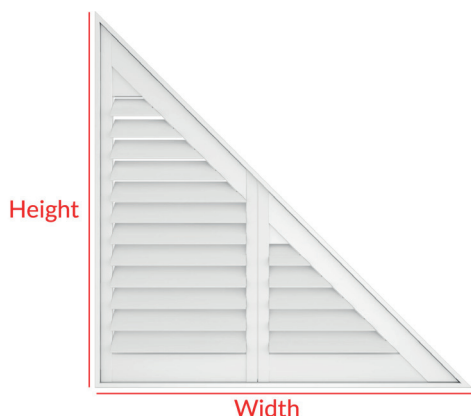

Hinge on Left

Triangle 2 Right

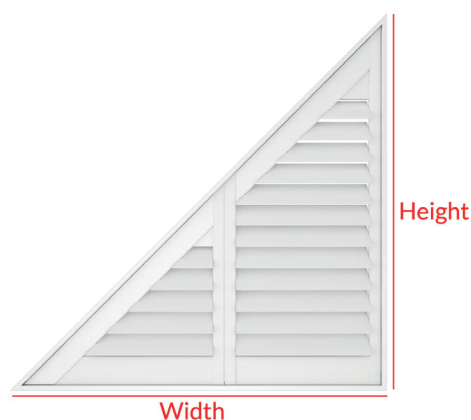

Hinge on Right

Pentagon

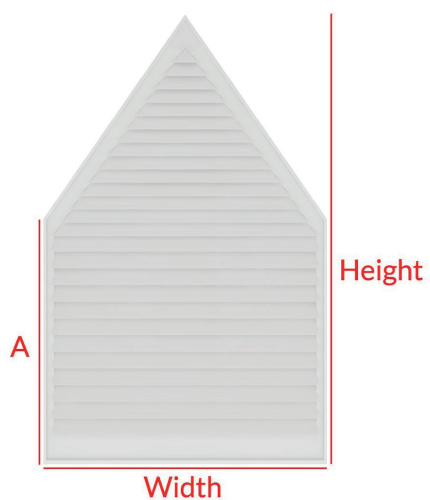

Elongated Pentagon Sunburst

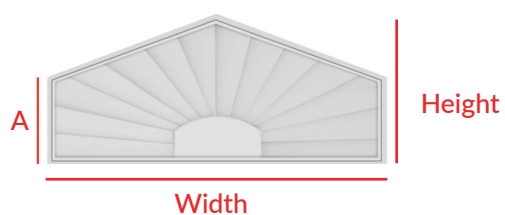

Diamond

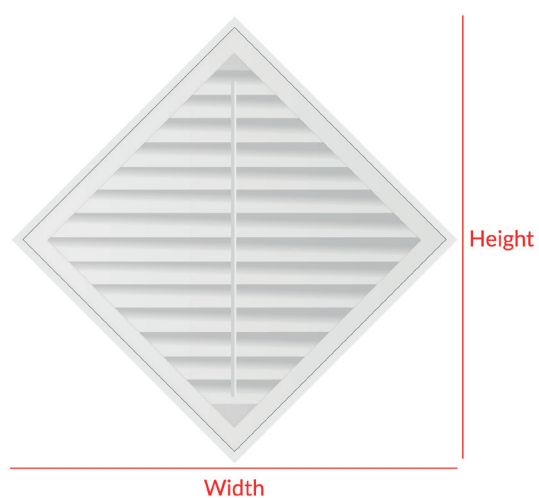

Please note:

Surcharge and longer lead time applies. A drawing must be signed off before production can begin.

French Door Type A

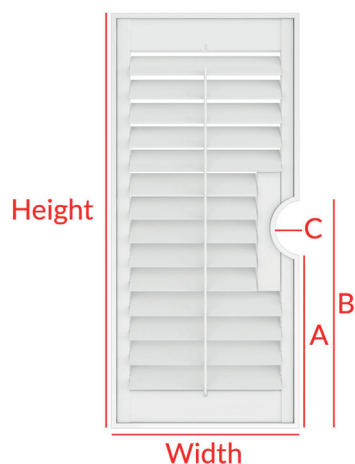

French Door Type C

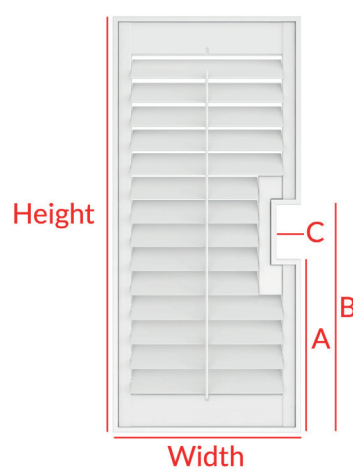

French Door, frame & panel screws directly onto door. Ensure the doors handle is positioned in the **centre** of the cut- out request as some door handles can lift upwards.

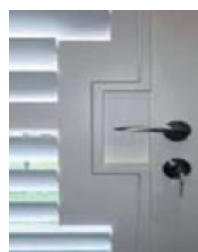

Confirm if you would like a light block board fitted or supplied loose for your fitter to install behind the frame cut out during installation. The light block board is 6mm thick plywood.

Please note:

Surcharge and longer lead time applies. A drawing must be signed off before production can begin.

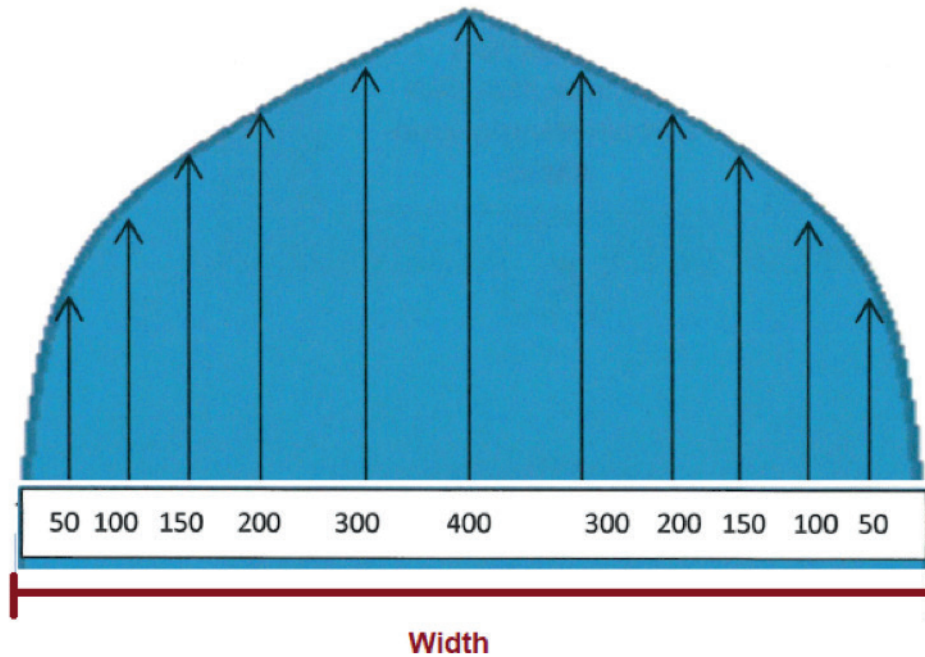

Gothic, Eyebrow and Non-Perfect Arches

Measure from the **very centre of the Width** to the top of the shape. Then measure the different heights at every 100mm out from the centre. For accuracy, measure at 50mm at either end. A Laser measure can be an effective tool during this type of survey.



Ensure you send your all information clearly on your order & drawing so that an accurate factory drawing can be requested.

Please note:
Surcharge and longer lead time applies. A drawing must be signed off before production can begin.